

APPLICATIONS OF THE OPTICAL-DIFFERENTIAL THERMAL ANALYSIS

JAROSLAV L. CASLAVSKY
U.S. ARMY MATERIALS TECHNOLOGY LABORATORY, WATERTOWN MA, 02172 USA

ABSTRACT

ODTA detects temperature contact-less, hence, it expands the upper usable temperature limit of DTA up to 3600°C accordingly suitable for studies of systems where enthalpic changes occur at high temperatures.

Application of the computer graphics for the evaluation of the ODTA curves is demonstrated on melting of $Y_2O_3 \cdot Al_2O_3$ and $YAlO_3$ - $GdAlO_3$ systems. Measurement errors occurring at temperatures above 1900°C are pointed out and possibilities for their elimination or at least diminution are discussed.

INTRODUCTION

The Optical Differential Thermal Analysis (ODTA) detects infrared radiation (IR) emitted by a sample heated inside the Black-Body Cavity (BBC). The BBC fulfills a dual function, it is the temperature source and the temperature reference standard.

BBC is a perfect radiator which emissivity is unity. The sample emissivity on the other hand, is a function of sample thermophysical and thermochemical properties, i.e., thermoradiative properties of the sample vary with the enthalpic changes taking place in the sample. In the great majority of cases changes of enthalpy and emissivity are in concert thereby enhancing the resolution of the inset of ΔT_{max} and/or ΔT_{min} peaks. This cooperation leads to a high sensitivity of the ODTA which allows $\Delta T/t$ rates to be as low as 0.1°C/min. Consequently, phase relations can be studied at almost equilibrium conditions.

ODTA APPARATUS

The ODTA apparatus consists of several parts: furnace with a power supply, furnace temperature control and a program system, two infrared pyrometers and a data acquisition system. With the exception of the furnace, most of the ODTA components are commercially available instruments. (The pyrometers are MAXLINE-SYSTEM M204, the furnace control and program system is MICRICON #82-300, manufactured by IRCON Inc. and RESEARCH Inc., respectively. The signal acquisition system consists of IBM-PC and IBM-AT.) For operation of the ODTA apparatus five independent microprocessors are required. Each has different digital characteristics, therefore, digital signals are converted to analog signals. To eliminate "cross talks", the D/A converters are mutually optically insulated. Numerous sources of such instruments are available, hence, the selection of particular instrumentation depends on the operational range of the ODTA, and, on individual preference. The furnace is the critical part of the ODTA apparatus. The furnace design will be briefly discussed next.

The cross-section of the ODTA furnace, capable to operate in the 700 to 2200°C range in a vacuum or an inert gas, is shown in fig. 1.

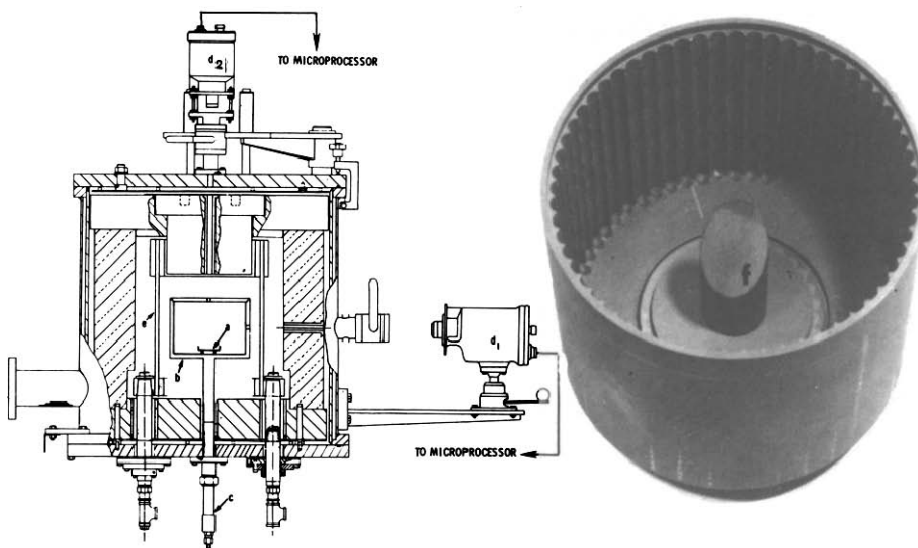

Fig. 1. Left: Cross-section of the ODTA furnace; right: The graphite Black-Body Cavity.

A Black-Body Cavity *b* is designed as a hollow cylinder positioned by the heat sink *c*, concentrically with the heating element *e*. The heat sink is water-cooled as to provide sufficient heat removal from the BBC, especially at cooling rates higher than 1.0°C/min. The sample *a* is placed inside the BBC at such a height that it does not interfere with the optical path of the radiometer *d*₁. The maximum wavelength varies over the ODTA temperature range. The wavelength of the IR radiation is a nonlinear function of the temperature. Thus the IR radiation is converted to the temperature by a digital linearization using the Planck's law.

Only few materials do not undergo enthalpic changes in the 1500-2200°C temperature range. Among such materials are graphite and molybdenum, which both were found suitable for manufacturing of the BBC. A graphite BBC is shown in Fig. 1 right. It is a hollow cylinder, which walls are corrugated to enhance the absorption of IR radiation. In the center of the bottom is a sample holder, now replaced with the calibration reflector *f*. During measurements, the top of BBC is closed with a lid. The lid has a circular opening for measuring the sample temperature with the pyrometer *d*₂. Pyrometer *d*₁ measures BBC temperature through an orifice in the side of the BBC (obscured in this view). Diameters of both orifices are calculated not to interfere with the optical path of either radiometer.

CALIBRATION

Two characteristics of optical pyrometers, the resolution power and

the repeatability, will ultimately determine the accuracy of the ODTA. Optical pyrometers with the $\pm 2^\circ\text{C}$ resolution power and the $\pm 1^\circ\text{C}$ repeatability are commercially available. Yet, even such a good quality instrument will produce a low frequency noise in the ODTA. An attempt to filter such a noise by a common type of a filter will necessarily diminish the accuracy and the sensitivity of the ODTA measurements. The measurements are complicated by the impossibility to apply the Lambert's law accurately, and, to determine precisely the value of the shape factor A . Hence, these factors must be treated separately, and all such corrections included in a single correction factor.

Optical pyrometers are relative instruments and as such, they have to be calibrated. This is done by using materials with well known melting points. Two calibrated pyrometers are mounted on the ODTA furnace. Both are focused on the singular spot of reflector bloc f Fig. 1 right. The difference in temperature readings between pyrometers d_1 and d_2 , can be explained by the Lambert law. The difference is eliminated by setting the temperature reading of pyrometer d_2 equal to that of pyrometer d_1 , stepwise over the entire temperature range.

A new temperature difference will occur when the calibration reflector f is replaced by the sample holder. This time, the difference in the pyrometer readings is caused by a change of the shape factor A . The temperature difference caused by the shape factor and by other incalculable errors is called the integrated furnace background. It's value is determined experimentally and used for calculation of differential (DT) curves from the (T) curves.

INTEGRATED FURNACE BACKGROUND.

The heat transfer at temperatures over 1000°C occurs predominantly by radiation. If both, the heater and the sample are at thermal equilibrium, there is no heat transfer either way. During thermal analysis, the sample temperature has to be increased or decreased. In both the cases, a thermal gradient between the heater and the sample must be established. The degree of the gradient is determined by the $\Delta T/t$ rate and the shape factor A . The degree of the gradient varies with temperature mainly due to the difference between the BBC and the sample emissivity. It is also effected by the furnace atmosphere. Values of these factors are particular to the furnace, the BBC and the sample materials i.e. to the setup of the entire ODTA apparatus. How these factors affect a (DT) curve is shown on the (DT) curve of melting of YAlO_3 in Fig. 2.

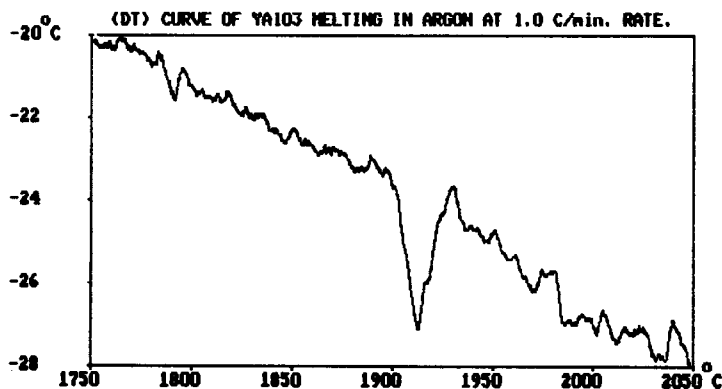

FIGURE 2.

For this reason, all the effectors are summarily determined and handled as an integrated furnace background (IFB). Due to the variability of these factors, the IFB has to be determined simultaneously with each individual measurement. For example, the (DT) curve shown in Fig. 2., now modified by the differentiation of the (T) curve with respect to the IFB, is shown in Fig.3.

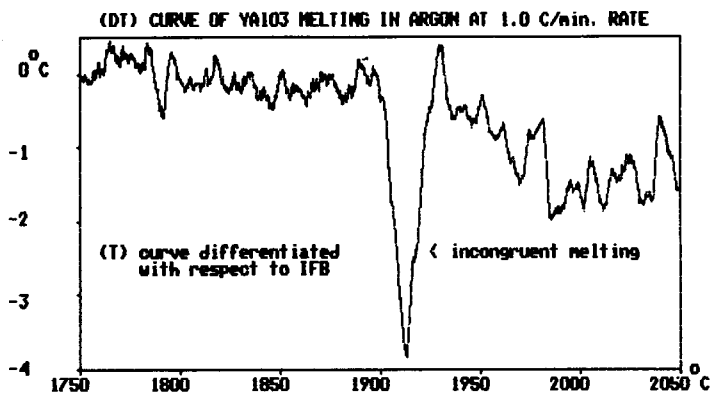

FIGURE 3.

SENSITIVITY AND REPRODUCIBILITY.

Yttrium and gadolinium aluminates form solid solutions over a large compositional range. Melting points of individual single phases differ only slightly. This makes it difficult to determine a phase diagram by the conventional methods. Dependence of the melting points of individual members on composition, i.e., a) $YAlO_3$; b) 90% $YAlO_3$ 10% $GdAlO_3$ and c) 75% $YAlO_3$ 25% $GdAlO_3$, is shown in Fig. 4.

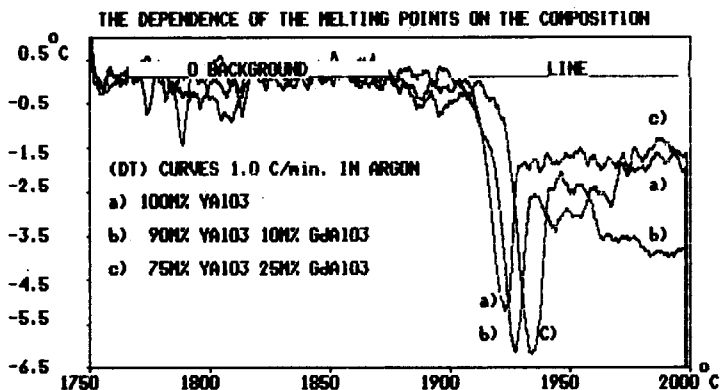

FIGURE 4.

The lower end of the ODTA measurement range was calibrated on the melting point of copper, while the upper end on the melting point of a single crystal of sapphire. The accuracy of the ODTA measurement was found to be $\pm 2^\circ\text{C}$ up to about 1700°C . Above this temperature, the error is larger. This is attributed to a particular melting behavior of sapphire¹. The reproducibility of the measurements as determined from several hundred experiments is $\pm 1^\circ\text{C}$; and is depicted in Fig. 5.

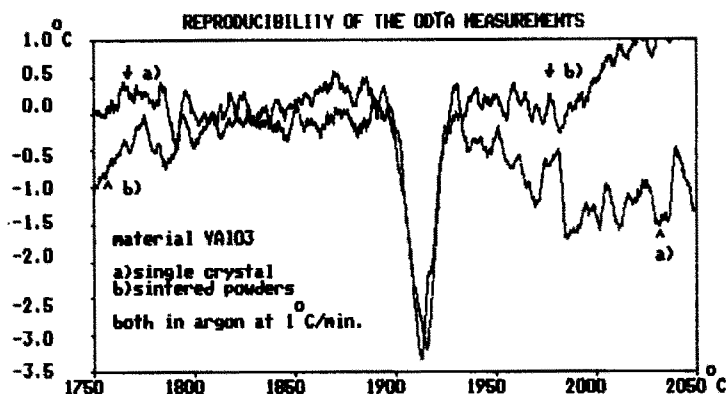

FIGURE 5.

Curve a) in Fig. 5 is the same as in Fig. 3. Curve b) is from a sintered mixture of the powders. The apparent absence of an indication of an incongruent melting on curve b) is not attributed to the method, rather it shows that pre-melted samples give more detailed information.

CONCLUSIONS

Previously, Rupert² used optical measurements to determine (DT) and (dT) curves, but his approach was different from the ODTA, as he used non-black body conditions and extremely high $\Delta T/t$ rates. In any case, the choice in methods is commanded by the specificity of needs.

Materials important for ceramists and crystal growers are studied at temperatures not reachable by conventional DTA instruments. Therefore, at the present time, there is a lack of data for comparison with the data obtained by the DDTA. Distinct advantage of the ODTA is in the fact that it is not necessary to amplify the sensors' signals, i.e. the signals are not treated electronically. The only refinement of the ODTA data is mathematical. This approach allows to analyze the results using various aspects of mathematical evaluation and, in case of uncertainty, it is again simple mathematically to modify the process.

The ODTA zero line or background is effected by numerous factors. Nevertheless, certain characteristics of the zero line contain a significant diagnostic information; hence, before any evaluation of the data is done, a careful study of the background data has to be made. Because the ODTA is a new technique, used in only one laboratory so far, there are no text books on its use and just few publications with which to confront the results. However, we believe that the ODTA is quite a potent technique, opening new approach for studying materials at high temperatures.

APPENDIX

An attempt is made here to refine the ODTA curves by a digital filter in order to view the ΔT peaks in a greater detail. The digital filter does not cause any shift along the abscissa. This approach is aimed to the ODTA application to discern invariant and univariant points, i.e., to distinct a solid solution from an incongruently melting compound. At this time, however, there is an insufficient experimental support for a positive proof.

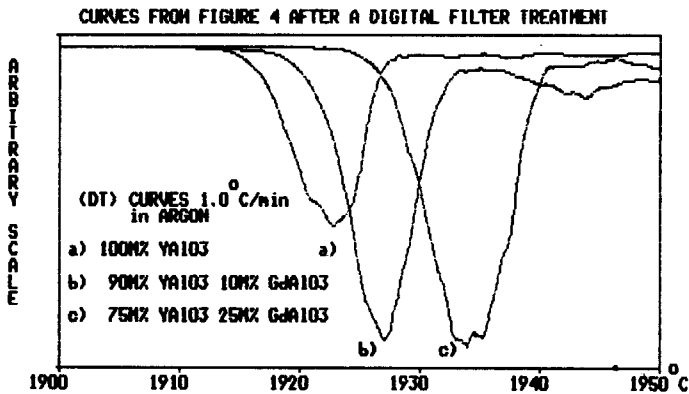

FIGURE 6.

ACKNOWLEDGMENT

The author wishes to express his thanks to R. Allen and G. Bryant of the MTL for their technical assistance and to E. Ramsden of the Boston University for the computer programming.

REFERENCES

- 1 J. L. Ceslevsky, Proceedings of the 9th International Congress for Thermal Analysis, Jerusalem, Israel, 1988.
- 2 J. L. Ceslevsky, Report # MTL TR 88-11 U.S. Army Materials Technology Laboratory Watertown, Massachusetts 02172-0001
- 3 G. N. Rupert, Rev. Sci. Instr. 36, 1629 (1965).